

Keysight Add 4-Port Capability Upgrade Kit

To Upgrade PNA-X N5244A or N5245A Option 224 to
Option 423

Upgrade Kit Order Numbers: N5244AU- 944 and
N5245AU- 944

Keysight Kit Number: N5245-60107

Notices

© Keysight Technologies, Inc.
2008-2015

No part of this manual may be reproduced in any form or by any means (including electronic storage and retrieval or translation into a foreign language) without prior agreement and written consent from Keysight Technologies, Inc. as governed by United States and international copyright laws.

Trademark Acknowledgments

Manual Part Number

N5245-90010

Edition

August 2015

Supersedes: February 2015

Printed in USA/Malaysia

Published by:
Keysight Technologies
1400 Fountaingrove Parkway
Santa Rosa, CA 95403

Warranty

THE MATERIAL CONTAINED IN THIS DOCUMENT IS PROVIDED "AS IS," AND IS SUBJECT TO BEING CHANGED, WITHOUT NOTICE, IN FUTURE EDITIONS. FURTHER, TO THE MAXIMUM EXTENT PERMITTED BY APPLICABLE LAW, KEYSIGHT DISCLAIMS ALL WARRANTIES, EITHER EXPRESS OR IMPLIED WITH REGARD TO THIS MANUAL AND ANY INFORMATION CONTAINED HEREIN, INCLUDING BUT NOT LIMITED TO THE IMPLIED WARRANTIES OF MERCHANTABILITY AND FITNESS FOR A PARTICULAR PURPOSE. KEYSIGHT SHALL NOT BE LIABLE FOR ERRORS OR FOR INCIDENTAL OR CONSEQUENTIAL DAMAGES IN CONNECTION WITH THE FURNISHING, USE, OR PERFORMANCE OF THIS DOCUMENT OR ANY INFORMATION CONTAINED HEREIN. SHOULD KEYSIGHT AND THE USER HAVE A SEPARATE WRITTEN AGREEMENT WITH WARRANTY TERMS

COVERING THE MATERIAL IN THIS DOCUMENT THAT CONFLICT WITH THESE TERMS, THE WARRANTY TERMS IN THE SEPARATE AGREEMENT WILL CONTROL.

Technology Licenses

The hardware and/or software described in this document are furnished under a license and may be used or copied only in accordance with the terms of such license.

U.S. Government Rights

The Software is "commercial computer software," as defined by Federal Acquisition Regulation ("FAR") 2.101. Pursuant to FAR 12.212 and 27.405-3 and Department of Defense FAR Supplement ("DFARS") 227.7202, the U.S. government acquires commercial computer software under the same terms by which the software is customarily provided to the public.

Accordingly, Keysight provides the Software to U.S. government customers under its standard commercial license, which is embodied in its End User License Agreement (EULA), a copy of which can be found at

<http://www.keysight.com/find/sweula>

The license set forth in the EULA represents the exclusive authority by which the U.S. government may use, modify, distribute, or disclose the Software. The EULA and the license set forth therein, does not require or permit, among other things, that Keysight: (1) Furnish technical information related to commercial computer software or commercial computer software documentation that is not customarily provided to the public; or (2) Relinquish to, or otherwise provide, the government rights in excess of these rights customarily provided to the public to use, modify, reproduce, release, perform, display, or disclose commercial computer software or commercial computer software

documentation. No additional government requirements beyond those set forth in the EULA shall apply, except to the extent that those terms, rights, or licenses are explicitly required from all providers of commercial computer software pursuant to the FAR and the DFARS and are set forth specifically in writing elsewhere in the EULA. Keysight shall be under no obligation to update, revise or otherwise modify the Software. With respect to any technical data as defined by FAR 2.101, pursuant to FAR 12.211 and 27.404.2 and DFARS 227.7102, the U.S. government acquires no greater than Limited Rights as defined in FAR 27.401 or DFAR 227.7103-5 (c), as applicable in any technical data.

Safety Notices

CAUTION

A **CAUTION** notice denotes a hazard. It calls attention to an operating procedure, practice, or the like that, if not correctly performed or adhered to, could result in damage to the product or loss of important data. Do not proceed beyond a CAUTION notice until the indicated conditions are fully understood and met.

WARNING

A **WARNING** notice denotes a hazard. It calls attention to an operating procedure, practice, or the like that, if not correctly performed or adhered to, could result in personal injury or death. Do not proceed beyond a WARNING notice until the indicated conditions are fully understood and met.

Keysight Add 4-Port Capability Upgrade Kit
Upgrade Kit Order Numbers: N5244AU- 944 and N5245AU-944

Installation Note

Description of the Upgrade

This upgrade converts your N5244A or N5245A Option 224 2-port analyzer to an N5244A or N5245A Option 423 4-port analyzer by adding:

- an additional mechanical switch
- an additional mixer brick
- two additional reference couplers
- two additional test port couplers
- two additional bias tees
- two additional source attenuators
- two additional receiver attenuators
- a splitter
- a modified front panel
- many new cables

Getting Assistance from Keysight

Installing this upgrade kit requires special skills and experience. If you think you may not be qualified to do the work, or need advice, contact Keysight.

Contacting Keysight

Assistance with test and measurements needs and information on finding a local Keysight office are available on the Web at:

<http://www.keysight.com/find/assist>

If you do not have access to the Internet, please contact your Keysight field engineer.

NOTE

In any correspondence or telephone conversation, refer to the Keysight product by its model number and full serial number. With this information, the Keysight representative can determine whether your product is still within its warranty period.

If You Have Problems With the Upgrade Kit Contents

Keysight stands behind the quality of the upgrade kit contents. If you have problems with any item in the kit, email Keysight Component Test Division (CTD) Support at support_ctd-soco@keysight.com, or telephone the CTD Hotline at (707) 577-6802 and leave a voice mail message. Please include details of the problem.

Getting Prepared

CAUTION

The PNA contains extremely sensitive components that can be ruined if mishandled. Follow instructions carefully when making cable connections, especially wire harness connections.

The person performing the work accepts responsibility for the full cost of the repair or replacement of damaged components.

To successfully install this upgrade kit, you will need the following:

- A license key - refer to **“License Key Redemption”** below.
- A PDF copy or a paper copy of the PNA Service Guide - refer to **“Downloading the Online PNA Service Guide”** below.
- An ESD-safe work area - refer to **“Protecting Your Workspace from Electrostatic Discharge”** below.
- Correct tools - refer to **“Tools Required for the Installation” on page 7**.
- Enough time - refer to **“About Installing the Upgrade” on page 7**.
- Test equipment for the post-upgrade adjustments and full instrument calibration. To view the equipment list, click the Chapter 3 bookmark “Tests and Adjustments” in the PDF Service Guide¹.

License Key Redemption

NOTE

The enclosed Option Entitlement Certificate is a receipt, verifying that you have purchased a licensed option for the PNA of your choice. You must now use an Keysight Web page to request a license key for the instrument that will receive the option.

To enable the option product, you must request a license key from: <http://www.keysight.com/find/softwarelicense>. To complete the request, you will need to gather the following information:

- From the certificate
 - Order number
 - Certificate number
- From your instrument
 - Model number
 - Serial number
 - Host ID

1. See **“Downloading the Online PNA Service Guide” on page 6**.

The instrument information is available on the network analyzer – on the analyzer’s Help menu, click About Network Analyzer.

If you provide an email address, Keysight will promptly email your license key. Otherwise, you will receive your license key via postal mail.

Downloading the Online PNA Service Guide

To view the online Service Guide for your PNA model number, use the following steps:

1. Go to www.keysight.com.
2. In the Search box, enter the model number of the analyzer (Ex: N5245A) and click **Search**.
3. Click **Technical Support > Manuals**.
4. Click **Service Manual**.
5. Click the service guide title to download the PDF file.
6. When the PDF of the Service Guide is displayed, scroll through the Contents section bookmarks to locate the information needed.

Protecting Your Workspace from Electrostatic Discharge

For information, click on the Chapter 1 bookmark, “Electrostatic Discharge Protection” in the PDF Service Guide¹.

ESD Equipment Required for the Installation

Description	Keysight Part Number
ESD grounding wrist strap	9300-1367
5-ft grounding cord for wrist strap	9300-0980
2 x 4 ft conductive table mat and 15-ft grounding wire	9300-0797
ESD heel strap (for use with conductive floors)	9300-1308

1. See [“Downloading the Online PNA Service Guide” on page 6](#).

Tools Required for the Installation

Description	Qty	Part Number
T-6 TORX driver - set to 4 in-lbs (0.45 N.m)	1	N/A
T-8 TORX driver - set to 6 in-lbs (0.68 N.m)	1	N/A
T-10 TORX driver - set to 9 in-lbs (1.02 N.m)	1	N/A
T-20 TORX driver - set to 21 in-lbs (2.38 N.m)	1	N/A
5/16-in (8 mm) nutsetter or open end torque wrench- set to 10 in-lbs (1.13 N.m)	1	N/A
5/16-in (8 mm) nutsetter or open end torque wrench - set to 21 in-lbs (2.38 N.m)	1	N/A
3/16-in (5 mm) nutsetter or open end torque wrench - set to 6 in-lbs (0.68 N.m)	1	N/A
5/8-in (16 mm) nutsetter or open end torque wrench - set to 21 in-lbs (2.38 N.m)	1	N/A
9 mm nutsetter or open end torque wrench - set to 21 in-lbs (2.38 N.m)	1	N/A
1-in (25.4 mm) torque wrench - set to 72 in-lbs (8.15 N.m)	1	N/A
1/4-in (6 mm) open end wrench	1	N/A

CAUTION

Use a 5/16-in torque wrench set to 10 in-lbs on all cable connections except the front and rear panel bulkhead connectors. On these, use a 9 mm nutsetter or open end torque wrench set to 21 in-lb.

About Installing the Upgrade

Products affected	N5244A and N5245A Option 224
Installation to be performed by	Keysight service center or personnel qualified by Keysight
Estimated installation time	5 hours
Estimated adjustment time	2 hours
Estimated full instrument calibration time	4.5 hours

Items Included in the Upgrade Kit¹

Check the contents of your kit against the following list. If any part is missing or damaged, contact Keysight Technologies. Refer to **“Getting Assistance from Keysight” on page 4.**

Table 1 Contents of Upgrade Kit N5245-60107

Ref Desig.	Description	Qty	Part Number
-	Installation note (this document)	1	N5245-90010
A28	Mixer brick (2)	1	5087-7323
A30	Test port 3 reference coupler	2	5087-7760
A31	Test port 4 reference coupler		Was 5086-7658
A34	Test port 3 coupler	2	5087-7793
A35	Test port 4 coupler		Was 5087-7724
A39	Test port 3 source attenuator	2	33325-60016
A40	Test port 4 source attenuator		Was 33325-60012
A43	Test port 3 bias tee (includes wire harness)	2	5087-7789
A44	Test port 4 bias tee (includes wire harness)		Was 5087-7331
A47	Test port 3 receiver attenuator	2	33325-60017
A48	Test port 4 receiver attenuator		Was 33325-60011
A52	Port 4 mechanical switch	1	N1811-60031
			Was N1811-60009
A26	Splitter	1	5067-4086
			Was 5086-7408
-	Front frame, diecast, 4-port	1	N5247-20141
			Was N5245-20128
-	Test set front plate, 4-port	1	N5224-00005
			Was N5245-00013
-	Machine screw, M3.0 x 6, flat head (to attach lower front dress panel to the test set front plate)	4	0515-1227
-	Machine screw, M2.5 x 20, pan head (2 to attach mechanical switch to bracket)	2	0515-1992
-	Machine screw, M2.0 x 6, flat head (8 to attach 2 reference couplers to brackets)	8	0515-1602

1. In addition to the upgrade kit, the shipment includes an Option Entitlement Certificate. Refer to **“License Key Redemption” on page 5** for important information about this certificate.

Table 1 Contents of Upgrade Kit N5245-60107

Ref Desig.	Description	Qty	Part Number
-	Machine screw, M3.0 x 25, pan head (3 to attach mixer brick A28 to mounting block)	3	0515-0667
-	Machine screw, M3.0 x 8, pan head (3 to attach shield to mixer brick; 8 to attach 2 src attn and 2 rcvr attn to brackets; 4 to attach 2 bias tee brackets to chassis)	15	0515-0372
-	Machine screw, M2.5 x 16, pan head (2 to attach splitter to mixer brick)	2	0515-2007
-	Machine screw, M3.0 x 10, pan head (4 to attach 2 reference coupler/bracket assemblies to deck)	4	0515-0374
-	Machine screw, M3.0 x 6, pan head (4 to attach 2 receiver attenuator/bracket assy. to deck; 2 to attach switch/bracket assy to deck; 4 to attach 2 source attenuator/bracket assy to deck)	10	0515-0430
-	Machine screw, M3.0 x 14, pan head (4 to attach 2 bias tees to brackets)	4	0515-2994 Was 0515-0665
-	Front panel overlay (label), 4-port	1	N5242-80003
-	Gap pad (between each coupler and test set front sub panel)	4	E4403-20033
-	Gap pad (between mixer brick A28 and shield)	4	N5245-20125
-	Shield, mixer brick	1	N5245-00023
A69	3 dB pad, attached to R4 connector on A28 mixer brick	1	08490-60010
-	50 ohm load, attached to W58 (N5245-20095)	1	1810-0118
-	Vibration mount (between couplers 1 & 3, and 2 & 4)	2	0460-2725
-	Mounting nuts (for port 3 & 4 test port couplers)	2	5022-1087
-	Cable guard, center jumper cables	1	N5242-00030
-	Cable clamp, 1 to secure W25 (N5245-20116) to deck; 1 to secure W29 (N5245-20117) to deck.	5	1400-1334
-	Cable tie wrap, 1 to secure W21 (N5245-20008) to side of deck	5	1400-0249
-	Bracket for port 4 mechanical switch	1	N5245-00014
-	Bracket for bias tee	2	N5245-00011
-	Bracket for reference coupler	2	N5245-00017
-	Bracket for receiver attenuator; bracket for source attenuator	4	N5245-00015
-	Dust caps for test ports	4	1401-0214
-	Termination, 2.4 mm 50 GHz load	1	0955-2394
W21	A29 port 1 reference coupler to A37 reference mixer switch	1	N5245-20008
W22	A33 port 1 coupler to front-panel Port 1 CPLR ARM	1	N5245-20014

Table 1 Contents of Upgrade Kit N5245-60107

Ref Desig.	Description	Qty	Part Number
W25	A30 port 3 ref coupler to front-panel REF 3 SOURCE OUT	1	N5245-20116
W26	A34 port 3 coupler to front-panel Port 3 CPLR ARM	1	N5245-20015
W29	A31 port 4 ref coupler to front-panel REF 4 SOURCE OUT	1	N5245-20117
W30	A35 port 4 coupler to front-panel Port 4 CPLR ARM	1	N5245-20018
W34	A36 port 2 coupler to front-panel Port 2 CPLR ARM	1	N5245-20019
W36	Front panel jumper	6	N5245-20155 Was N5245-20104
W44	REF 3 RCVR R3 IN to A28 mixer brick (R3)	1	N5245-20020
W45	REF 4 RCVR R4 IN to A69 3 dB pad on A28 mixer brick (R4)	1	N5245-20021
W46	REF 2 RCVR R2 IN to A27 mixer brick (R2)	1	N5245-20115
W52	A25 HMA26.5 to A26 splitter	1	N5245-20013
W53	A26 splitter to A27 mixer brick	1	N5245-20023
W54	A26 splitter to A28 mixer brick	1	N5245-20022
W58	A28 mixer brick to 50 ohm load (1810-0118)	1	N5245-20095
W62	A27 mixer brick (R1) to A24 IF multiplexer (P411)	1	N5242-60021
W63	A27 mixer brick (R2) to A24 IF multiplexer (P412)	1	N5242-60022
W65	A28 mixer brick (D) to A24 IF multiplexer (P801)	1	N5242-60024
W66	A28 mixer brick (R4) to A24 IF multiplexer (P414)	1	N5242-60019
W67	A28 mixer brick (R3) to A24 IF multiplexer (P413)	1	N5242-60020
W68	A28 mixer brick (C) to A24 IF multiplexer (P601)	1	N5242-60023
W70	A20 IF multiplexer (P203) to A12 SPAM (J2)	1	N5242-60013
W72	A20 IF multiplexer (P603) to A12 SPAM (J5)	1	N5242-60015
W84	A42 port 1 bias tee to front panel port 1 CPLR THRU	1	N5245-20085
W85	A30 port 3 reference coupler to A39 port 3 source attenuator	1	N5245-20026
W86	A39 port 3 source attenuator to front-panel Port 3 SOURCE OUT	1	N5245-20027
W87	Port 3 CPLR THRU to A43 port 3 bias tee	1	N5245-20089
W88	A43 port 3 bias tee to A34 port 3 coupler	1	N5245-20086
W89	A31 port 4 reference coupler to A40 port 4 source attenuator	1	N5245-20026
W90	A40 port 4 source attenuator to front-panel Port 4 SOURCE OUT	1	N5245-20028
W91	Port 4 CPLR THRU to A44 port 4 bias tee	1	N5245-20090

Table 1 Contents of Upgrade Kit N5245-60107

Ref Desig.	Description	Qty	Part Number
W92	A44 port 4 bias tee to A35 port 4 coupler	1	N5245-20088
W96	A45 port 2 bias tee to front panel port 2 CPLR THRU	1	N5245-20087
W99	Port 3 RCVR C IN to A47 port 3 receiver attenuator	1	N5245-20073
W100	A47 port 3 receiver attenuator to A28 mixer brick (C)	1	N5245-20066
W101	Port 4 RCVR D IN to A48 port 4 receiver attenuator	1	N5245-20074
W102	A48 port 4 receiver attenuator to A28 mixer brick (D)	1	N5245-20075
W112	A51 port 3 source bypass switch to A30 port 3 reference coupler	1	N5245-20059
W115	A52 port 4 source bypass switch to W15	1	N5245-20060
W116	A52 port 4 source bypass switch to A31 port 4 reference coupler	1	N5245-20061
W117	A52 port 4 source bypass switch to rear panel PORT 4 SW SRC OUT (J4)	1	N5245-20092
W118	A52 port 4 source bypass switch to rear panel PORT 4 SW TSET (J3)	1	N5245-20091
W123	Rear panel jumper	1	N5245-20155 Was N5245-20104
-	Ribbon cable, A23 test set motherboard J547 to A39 port 3 source attenuator	2	N5245-60006
-	Ribbon cable, A23 test set motherboard J548 to A40 port 4 source attenuator		
-	Ribbon cable, A23 test set motherboard J206 to A47 port 3 receiver attenuator	2	N5245-60026 Was 8121-0982, or N5242-60007
-	Ribbon cable, A23 test set motherboard J207 to A48 port 4 receiver attenuator		
-	Ribbon cable, A23 test set motherboard J552 to A28 mixer brick (2) J52	1	N5247-60015
-	Wire assembly, A23 test set motherboard J221 to ports 1/3 LED board J1	2	N5225-60001
-	Wire assembly, A23 test set motherboard J222 to ports 2/4 LED board J1		

NOTE

Extra quantities of items such as protective plastic caps, screws, cable ties, and cable clamps may be included in this upgrade kit. It is normal for some of these items to remain unused after the upgrade is completed.

Installation Procedure for the Upgrade

The network analyzer must be in proper working condition prior to installing this option. Any necessary repairs must be made before proceeding with this installation.

WARNING

This installation requires the removal of the analyzer's protective outer covers. The analyzer must be powered down and disconnected from the mains supply before performing this procedure.

Overview of the Installation Procedure

- “Step 1. Obtain a Keyword and Verify the Information.”
- “Step 2. Remove the Outer Cover.”
- “Step 3. Remove the Inner Cover.”
- “Step 4. Remove the Front Panel Assembly.”
- “Step 5. Remove the A23 Test Set Motherboard.”
- “Step 6. Remove the A24 IF Multiplexer Board.”
- “Step 7. Remove Some Cables.”
- “Step 8. Remove the A27 Mixer Brick Assembly.”
- “Step 9. Assemble the A28 Mixer Brick Assembly.”
- “Step 10. Install the A27/A28 Mixer Bricks Assembly.”
- “Step 11. Assemble the A30 and A31 Reference Coupler Assemblies.”
- “Step 12. Install the A30 and A31 Reference Coupler Assemblies.”
- “Step 13. Assemble the A47 and A48 Receiver Attenuator Assemblies.”
- “Step 14. Install the A47 and A48 Receiver Attenuator Assemblies.”
- “Step 15. Assemble the A39 and A40 Source Attenuator Assemblies.”
- “Step 16. Install the A39 and A40 Source Attenuator Assemblies.”
- “Step 17. Install the Bias Tee Brackets.”
- “Step 18. Install the A43 and A44 Bias Tees.”
- “Step 19. Assemble the A52 Port 4 Mechanical Switch Assembly.”
- “Step 20. Install the A52 Port 4 Mechanical Switch Assembly.”
- “Step 21. Assemble the A33 - A36 Test Port Coupler Assemblies.”
- “Step 22. Install the LED Boards and Test Port Coupler Assemblies to the Test Set Front Plate.”

“Step 23. Install the Coupler Plate Assembly to the Deck.”

“Step 24. Install the Test Set Cables.”

“Step 25. Secure the Front Panel Bulkhead Connectors.”

“Step 26. Reinstall the A24 IF Multiplexer Board.”

“Step 27. Reinstall the A23 Test Set Motherboard.”

“Step 28. Disassemble the 2-Port Front Panel and Assemble the 4-Port Front Panel.”

“Step 29. Reinstall Front Panel Assembly.”

“Step 30. Install the Overlays” on page 33

“Step 31. Install the Jumper Cables and Rear Panel Termination.”

“Step 32. Position the Cables and Wires to Prevent Pinching.”

“Step 33. Reinstall the Inner Cover.”

“Step 34. Reinstall the Outer Cover.”

“Step 35. Remove Option 224 and Option 219 Licenses.”

“Step 37. Perform Post-Upgrade Adjustments and Calibration.”

“Step 38. Prepare the PNA for the User.”

Step 1. Obtain a Keyword and Verify the Information

Follow the instructions on the Option Entitlement Certificate supplied to obtain a license key for installation of this upgrade. Refer to **“License Key Redemption” on page 5**.

Verify that the model number, serial number, and option number information on the license key match those of the instrument on which this upgrade will be installed.

If the model number, serial number, or option number do not match those on your license key, you will not be able to install the option. If this is the case, contact Keysight for assistance before beginning the installation of this upgrade. Refer to **“Contacting Keysight” on page 4**.

Once the license key has been received and the information verified, you can proceed with the installation at step 2.

Step 2. Remove the Outer Cover

For instructions, click the Chapter 7 bookmark “Removing the Covers” in the PDF Service Guide¹.

1. See **“Downloading the Online PNA Service Guide” on page 6**.

Step 3. Remove the Inner Cover

For instructions, click the Chapter 7 bookmark “Removing the Covers” in the PDF Service Guide¹.

Step 4. Remove the Front Panel Assembly

For instructions, click the Chapter 7 bookmark “Removing and Replacing the Front Panel Assembly” in the PDF Service Guide¹.

Step 5. Remove the A23 Test Set Motherboard

For instructions, click the Chapter 7 bookmark “Removing and Replacing the A23 Test Set Motherboard” in the PDF Service Guide¹.

Step 6. Remove the A24 IF Multiplexer Board

For instructions, click the Chapter 7 bookmark “Removing and Replacing the A24 IF Multiplexer Board” in the PDF Service Guide¹.

Step 7. Remove Some Cables

CAUTION

Be careful not to damage the center pins of the semirigid cables. Some flexing of the cables may be necessary but do not over-bend them.

NOTE

Leave the gray flexible cables, the wire harnesses, and the ribbon cables connected where possible. Any that are removed should be labeled for reconnection later.

NOTE

When removing a cable, also remove the plastic cable clamp, if present. It is normal for some of the cable clamp’s adhesive to remain.

1. Place the analyzer bottom-side up on a flat surface.
2. Remove and discard the following gray flexible cables:
 - W130 A20 IF multiplexer (P203) to A12 SPAM (J5)
 - W129 A20 IF multiplexer (P603) to A12 SPAM (J2)
3. Remove all bottom-side (test set) semirigid cables except for those in the following table. Do not discard the cables that are removed because some will be reused later in the procedure.
To see an image showing the location of cables W11, W13, W17, and W51 click the Chapter 6 bookmark “Top Cables, All Cables - All Options” in

the PDF Service Guide¹. To see an image showing the location of the other cables, click the Chapter 6 bookmark “Bottom RF Cables, 2-Port, Option 224” in the PDF Service Guide¹.

Reference Designator	Type ^a	Part Number	Qty	Description
W11	SR	N5245-20036	1	A7 port 1 doubler to W105
W13	SR	N5245-20036	1	A12 port 3 doubler to W14
W15	SR	N5245-20036	1	A13 port 4 doubler to W16
W17	SR	N5245-20036	1	A8 port 2 doubler to W18
W51	SR	N5245-20101	1	A15 13.5 GHz (LO) synthesizer board J1207 to A25 HMA26.5
W55	SR	N5245-20102	1	A7 port 1 doubler to W56
W56	SR	N5245-20103	1	W55 to rear-panel EXT TSET DRIVE RF OUT (J6)
W57	SR	N5245-20012	1	A27 mixer brick to EXT TSET DRIVE LO OUT (J5)
W107	SR	N5245-20068	1	A50 port 1 source bypass switch to rear panel PORT 1 SW SRC OUT (J11)
W108	SR	N5245-20094	1	Rear-panel PORT 1 COMB THRU IN (J10) to A54 combiner
W109	SR	N5245-20093	1	Rear-panel PORT 1 COMB ARM IN (J9) to A54 combiner
W113	SR	N5245-20069	1	A51 SRC2 OUT1 source bypass switch to rear panel PORT 3 SW SRC OUT (J8)
W114	SR	N5245-20070	1	Rear-panel PORT 3 SW TSET IN (J7) to A51 SRC2 OUT1 source bypass switch
W121	SR	N5245-20071	1	A53 port 2 source bypass switch to rear panel PORT 2 SW SRC OUT (J2)
W122	SR	N5245-20072	1	A53 port 2 source bypass switch to PORT 2 TSET IN (J1)

a. SR = semirigid coaxial cable.

4. Remove and discard the following gray flexible cables:

- W62 (N5242-60025) A27 mixer brick (R1) to A24 IF multiplexer (P601)
- W63 (N5242-60026) A27 mixer brick (R2) to A24 IF multiplexer (P801)

5. Leave the remaining gray flexible cables, the wire harnesses, and the ribbon cables connected where possible. Any that are removed should be labeled for reconnection later.

1. See “[Downloading the Online PNA Service Guide](#)” on page 6.

Step 8. Remove the A27 Mixer Brick Assembly

Remove the A27 mixer brick assembly from the PNA. For instructions, click the Chapter 7 bookmark, "Removing and Replacing the A27 and A28 Mixer Bricks" in the PDF Service Guide¹.

Step 9. Assemble the A28 Mixer Brick Assembly

1. Follow the two instructions shown in **Figure 1**. New parts are listed in **Table 1 on page 8** of this document.

Figure 1

A28 Mixer Brick Assembly

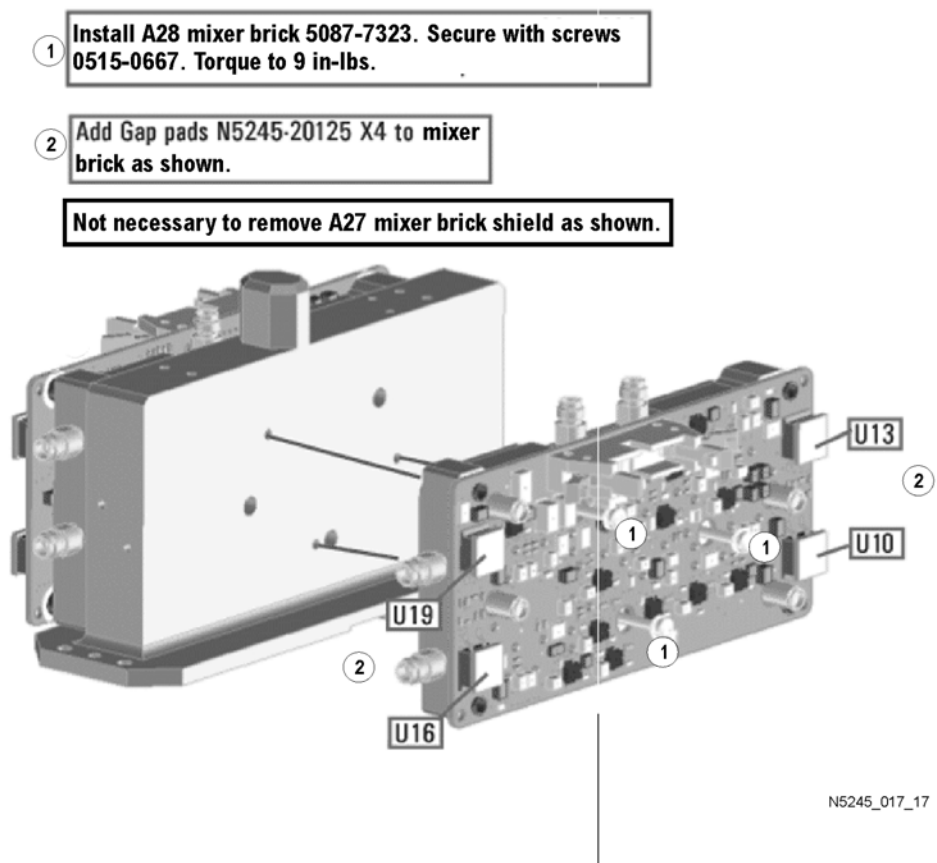

1. See ["Downloading the Online PNA Service Guide"](#) on page 6.

2. Follow the four instructions shown in **Figure 2**.

Figure 2 Shields, Splitter, and 3 dB Pad Installation

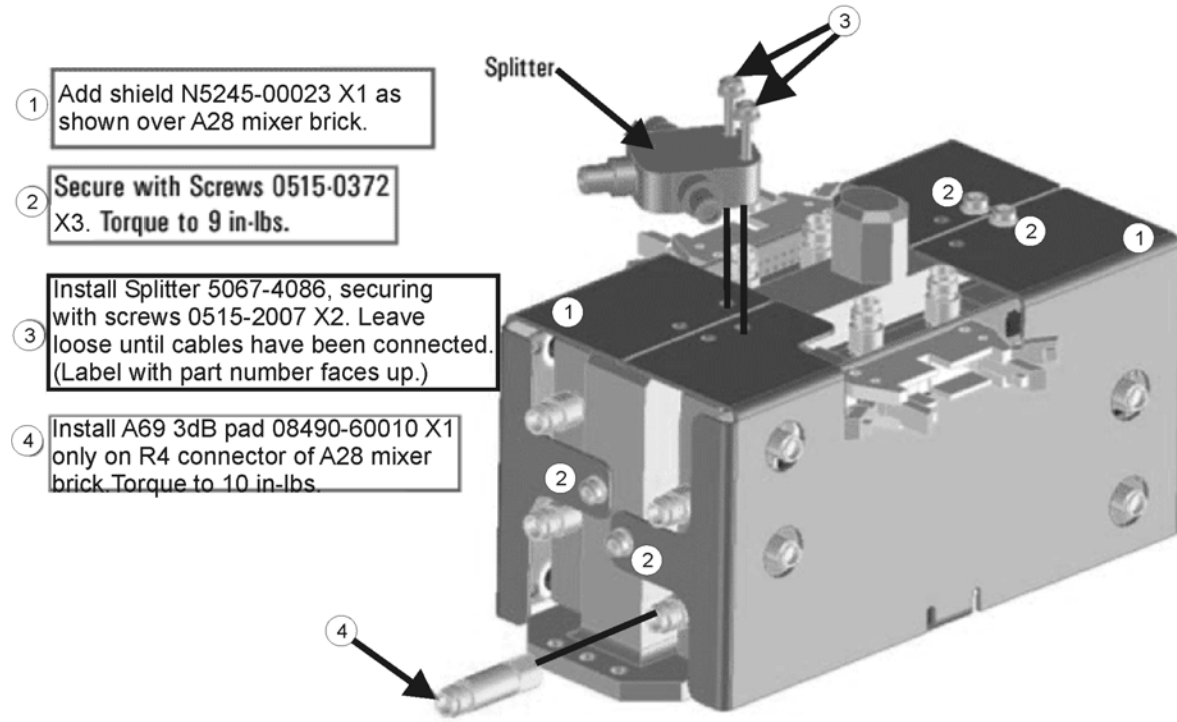

N5245_016_18

3. Connect the gray flexible cables in the order shown in **Figure 3**.

NOTE

Graphics in this document such as **Figure 3** use very brief text to instruct where to connect a cable. For example, text that reads “N5242-60018 IFMUX P201 - BRK1 B” means to connect the N5242-60018 gray flexible cable at the A24 IF MUX board connector P201 and at A27 Mixer Brick 1 connector B.

Figure 3 A28 Mixer Brick Cable Installation

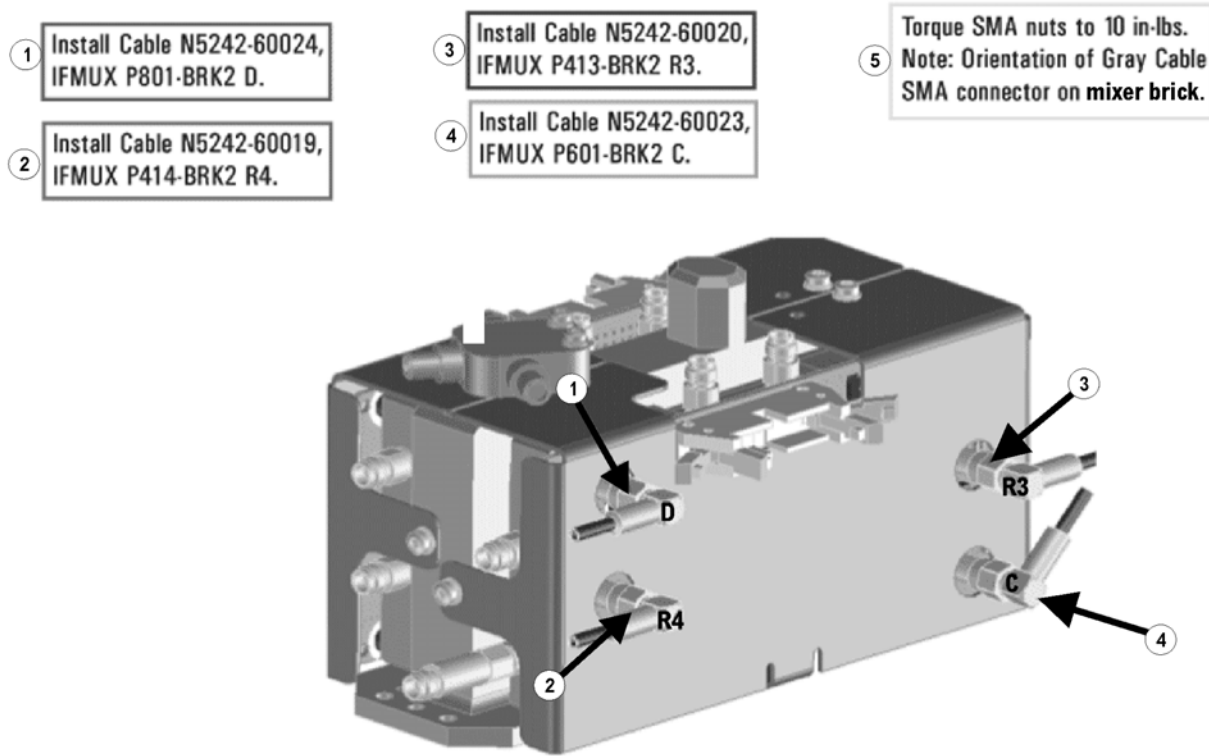

N5245_017_19

Step 10. Install the A27/A28 Mixer Bricks Assembly

Install the A27/A28 mixer brick assembly, reusing the 4 existing screws. For instructions, click the Chapter 7 bookmark, “Removing and Replacing the A27 and A28 Mixer Bricks” in the PDF Service Guide¹. New parts are listed in **Table 1 on page 8** of this document

Step 11. Assemble the A30 and A31 Reference Coupler Assemblies

Follow the instruction shown in **Figure 4**. New parts are listed in **Table 1 on page 8** of this document.

1. See “[Downloading the Online PNA Service Guide](#)” on page 6.

Figure 4 A30 and A31 Reference Coupler Assembly

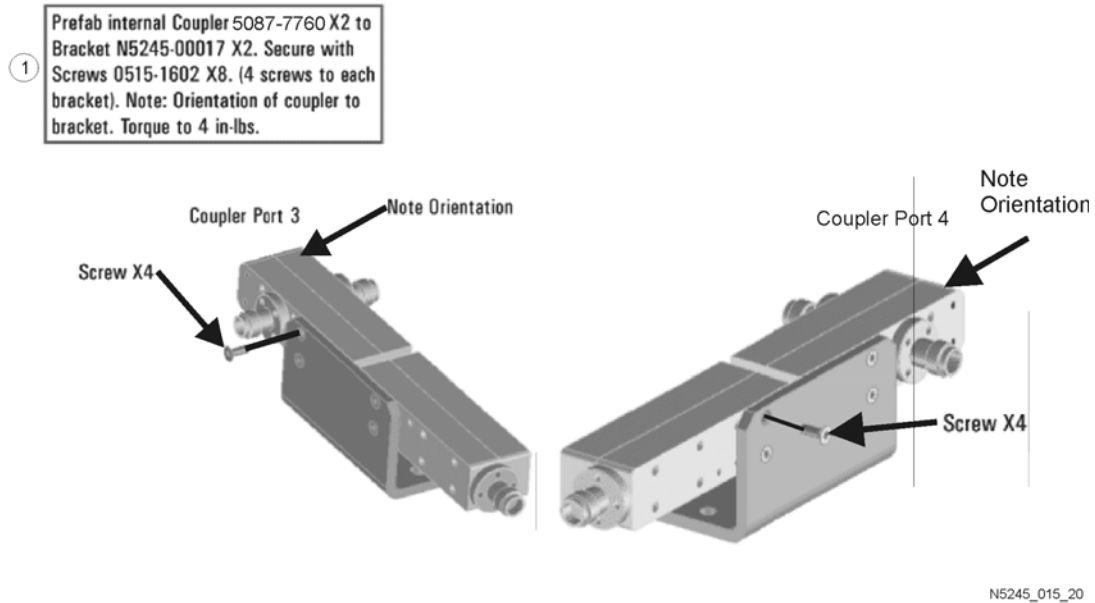

Step 12. Install the A30 and A31 Reference Coupler Assemblies

Install the A30 and A31 reference coupler assemblies. For instructions, click the Chapter 7 bookmark, “Removing and Replacing the A29-A32 Reference Couplers and Reference Coupler Mounting Brackets” in the PDF Service Guide¹. New parts are listed in [Table 1 on page 8](#) of this document.

Step 13. Assemble the A47 and A48 Receiver Attenuator Assemblies

Assemble the A47 and A48 receiver attenuator assemblies. For instructions, click the Chapter 7 bookmark, “Removing and Replacing the A38-A41 Source Attenuators and the A46-A49 Receiver Attenuators” in the PDF Service Guide¹. New parts are listed in [Table 1 on page 8](#) of this document.

Step 14. Install the A47 and A48 Receiver Attenuator Assemblies

Install the A47 and A48 receiver attenuator assemblies. For instructions, click the Chapter 7 bookmark, “Removing and Replacing the A38-A41 Source Attenuators and the A46-A49 Receiver Attenuators” in the PDF Service Guide¹. New parts are listed in [Table 1 on page 8](#) of this document.

Step 15. Assemble the A39 and A40 Source Attenuator Assemblies

Assemble the A39 and A40 source attenuator assemblies. For instructions, click the Chapter 7 bookmark, “Removing and Replacing the A38-A41 Source Attenuators and the A46-A49 Receiver Attenuators” in the PDF Service Guide¹. New parts are listed in **Table 1 on page 8** of this document.

Step 16. Install the A39 and A40 Source Attenuator Assemblies

Install the A39 and A40 source attenuator assemblies. For instructions, click the Chapter 7 bookmark, “Removing and Replacing the A38-A41 Source Attenuators and the A46-A49 Receiver Attenuators” in the PDF Service Guide¹.

Step 17. Install the Bias Tee Brackets

Refer to **Figure 5** for this step of the procedure. New parts are listed in **Table 1 on page 8**.

Figure 5 Bias Tee Brackets Installation

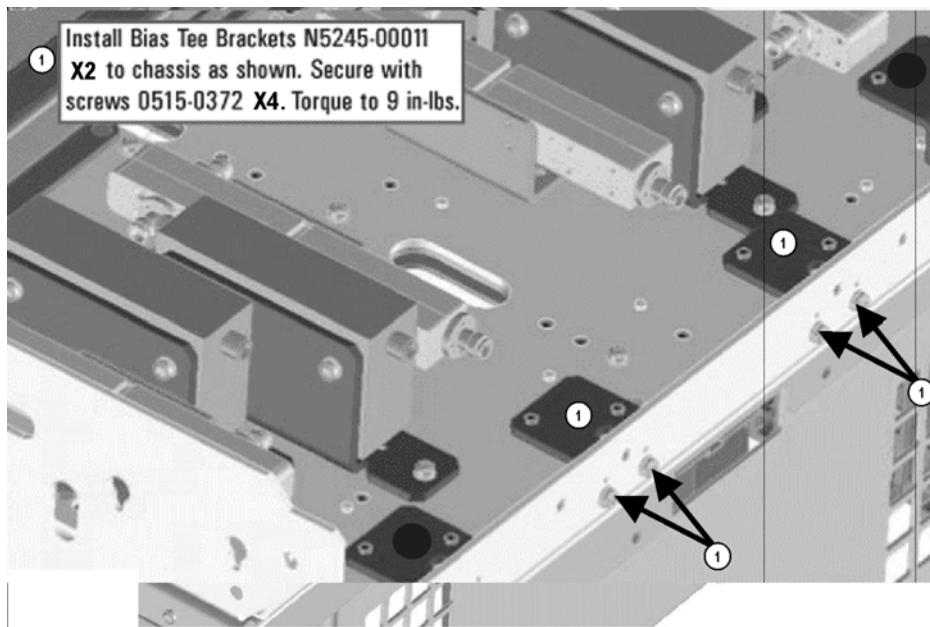

N5245_017_21

1. See “[Downloading the Online PNA Service Guide](#)” on page 6.

Step 18. Install the A43 and A44 Bias Tees

Install the A43 and A44 bias tees. For instructions, click the Chapter 7 bookmark, “Removing and Replacing the A42-A45 Bias Tees” in the PDF Service Guide¹. New parts are listed in [Table 1 on page 8](#) of this document.

NOTE

Orient the port 3 bias tee so that the capacitor faces that on the port 1 bias tee. Likewise, port 2 and port 4 bias tee capacitors should face each other. Also, fasten each bias tee’s red wire lug nut using the screw on the side of the bias tee without a capacitor.

Step 19. Assemble the A52 Port 4 Mechanical Switch Assembly

Refer to [Figure 6](#) for this step of the procedure. New parts are listed in [Table 1 on page 8](#).

Figure 6

A52 Port 4 Mechanical Switch Assembly

- ① Prefab switch N1811-60031 to bracket N5245-00014 as shown. Secure with screws 0515-1992 X2. Torque to 6 in-lbs.

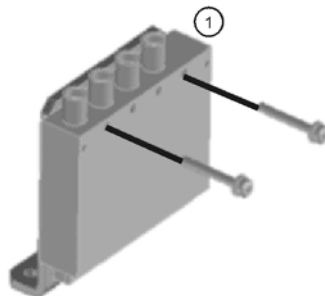

N5245_017_22

Step 20. Install the A52 Port 4 Mechanical Switch Assembly

Install the A52 mechanical switch. For instructions, click the Chapter 7 bookmark, “Removing and Replacing the A50-A53 Mechanical Switches and the A54 Combiner” in the PDF Service Guide¹. New parts are listed in [Table 1 on page 8](#) of this document.

Step 21. Assemble the A33 - A36 Test Port Coupler Assemblies

1. Remove the A33 test port 1 coupler and A36 test port 2 coupler from the PNA. For instructions, click the Chapter 7 bookmark, "Removing and Replacing the A33 - A36 Test Port Couplers" in the PDF Service Guide¹.
2. Using pliers, remove the adhesive bumper on the A33 test port 1 coupler and on the A36 test port 2 coupler.
3. Follow the two instructions shown in **Figure 7**. New parts are listed in **Table 1 on page 8** of this document.

Figure 7

A33 - A36 Test Port Coupler Assembly

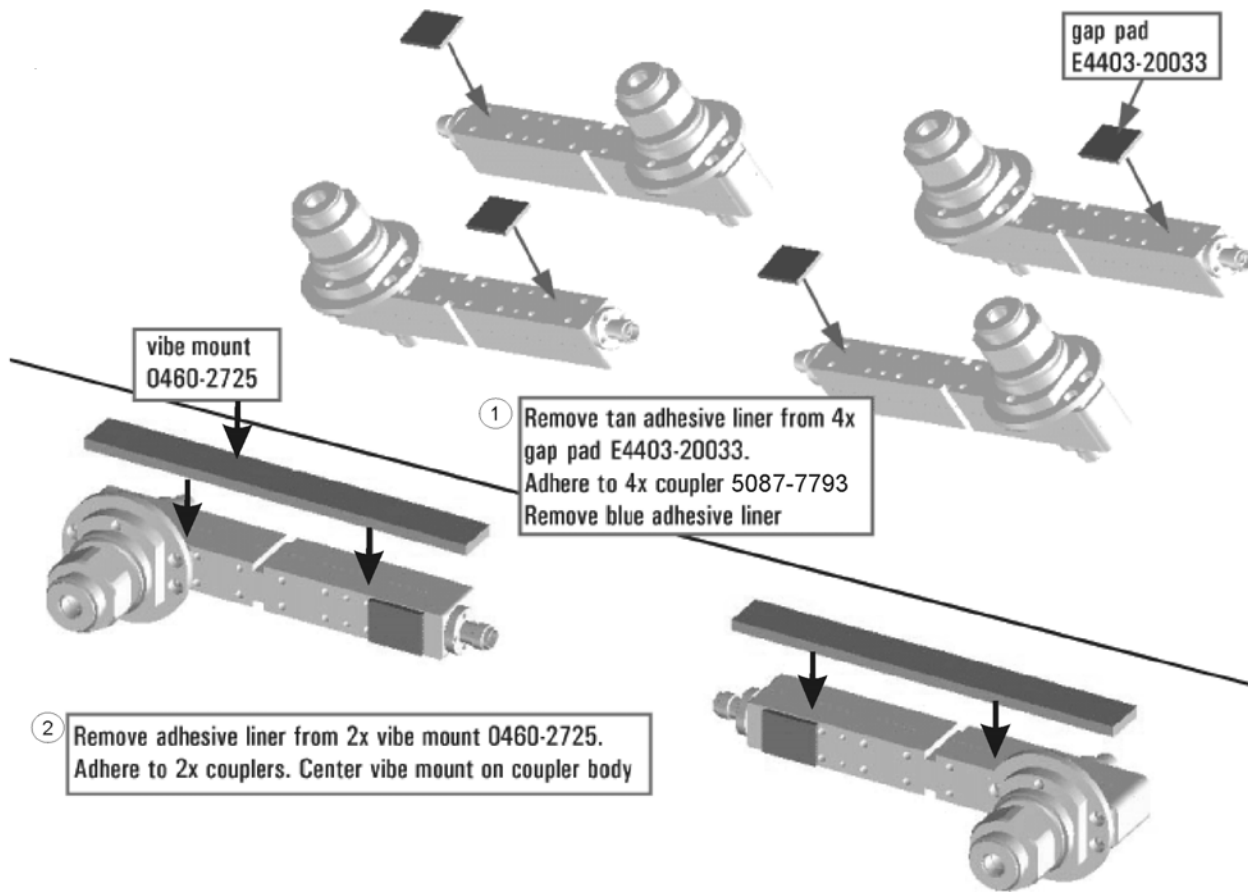

N5245_017_11

Step 22. Install the LED Boards and Test Port Coupler Assemblies to the Test Set Front Plate

1. Remove two screws from each LED board and remove the boards from the 2-port test set front plate of the PNA.

1. See "[Downloading the Online PNA Service Guide](#)" on page 6.

2. Remove the 2-port test set front plate from the test set deck.
3. Follow the instructions shown in **Figure 8**.

Figure 8

LED Board Assemblies and Test Port Coupler Assemblies Installation

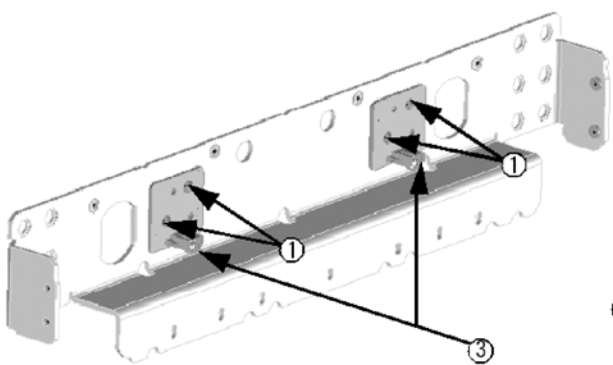

① Secure 2x LED boards to new test set front plate N5224-00005, reusing 4x screws. NOTE: Look closely at graphic - LED boards may be oriented differently on new test set front plate than on original test set front plate.

② Prefab 4x couplers 5087-7793 onto front plate. Note: Port 1/3 and 2/4 couplers must be installed at the same time. **Hand-tighten** 4x mounting nuts 5022-1087 (reuse 2x mounting nuts). **Do not torque.**

③ Replace both original LED wire harnesses with new LED wire harnesses N5225-60001.

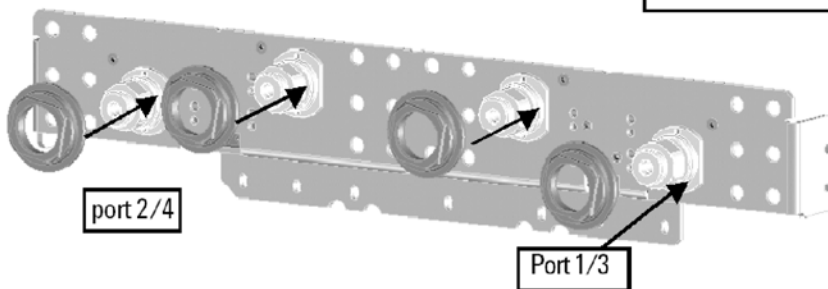

N5245_017_12

Step 23. Install the Coupler Plate Assembly to the Deck

Follow the four instructions shown in **Figure 9**.

Figure 9 Coupler Plate Assembly Installation

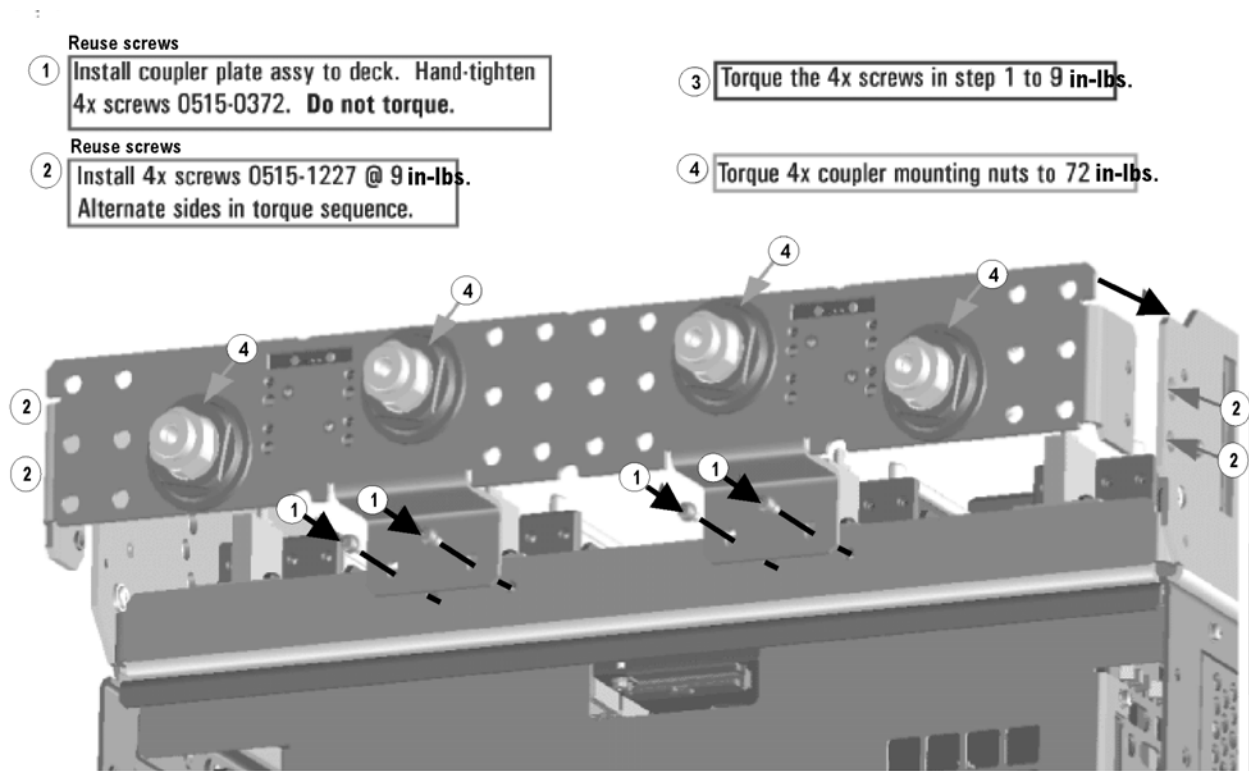

N5245_017_13

Step 24. Install the Test Set Cables

CAUTION

Follow instructions carefully when making cable connections, especially wire harness connections. Incorrect connections can destroy components, resulting in additional customer costs.

CAUTION

Be careful not to damage the center pins of the semirigid cables. Some flexing of the cables may be necessary but do not over-bend them.

CAUTION

Use a 5/16-in torque wrench set to 10 in-lbs on all cable connections except the front and rear panel bulkhead connectors. On these, use a 9 mm nutsetter or open end torque wrench set to 21 in-lb.

Flexible Cables Required for Upgrading to an Option 423 PNA

Install the following flexible cables in the order listed. To see images showing the location of these cables, click either of the Chapter 6 bookmarks “Bottom RF Cables, 4-Port, Option 423” in the PDF Service Guide¹. New parts are listed in [Table 1 on page 8](#).

- W62 (N5242-60021) A27 mixer brick (R1) to A24 IF multiplexer (P411)
- W63 (N5242-60022) A27 mixer brick (R2) to A24 IF multiplexer (P412)

Semirigid Cables Required for Upgrading to an Option 423 PNA

To see images showing the location of these cables, click the Chapter 6 bookmark “Bottom RF Cables, 4-Port, Option 423” in the PDF Service Guide¹. New parts are listed in [Table 1 on page 8](#).

- W118 (N5245-20091) A52 port 4 mechanical switch to PORT 4 SW TSET (J3).
- W117 (N5245-20092) A52 port 4 mechanical switch to PORT 4 SW SRC OUT (J4)
- W96 (N5245-20087) A45 port 2 bias tee to A36 port 2 coupler
- W92 (N5245-20088) A44 port 4 bias tee to A35 port 4 coupler
- W84 (N5245-20085) A42 port 1 bias tee to A33 port 1 coupler
- W88 (N5245-20086) A43 port 3 bias tee to A34 port 3 coupler
- W120 (reuse) (N5245-20062) A53 port 2 mechanical switch to A32 port 2 reference coupler
- W116 (N5245-20061) A52 port 4 mechanical switch to A31 port 4 reference coupler

1. See [“Downloading the Online PNA Service Guide” on page 6](#).

Installation Procedure for the Upgrade

- W112 (N5245-20059)A51 port 3 mechanical switch to A30 port 3 reference coupler
- W25 (N5245-20116) A30 port 3 ref coupler to front-panel REF 3 SOURCE OUT

* As shown in **Figure 10**, install clamp part number 1400-1334 to secure W25

Figure 10 Location of Cable Clamp to Secure W25 (N5245-20116)

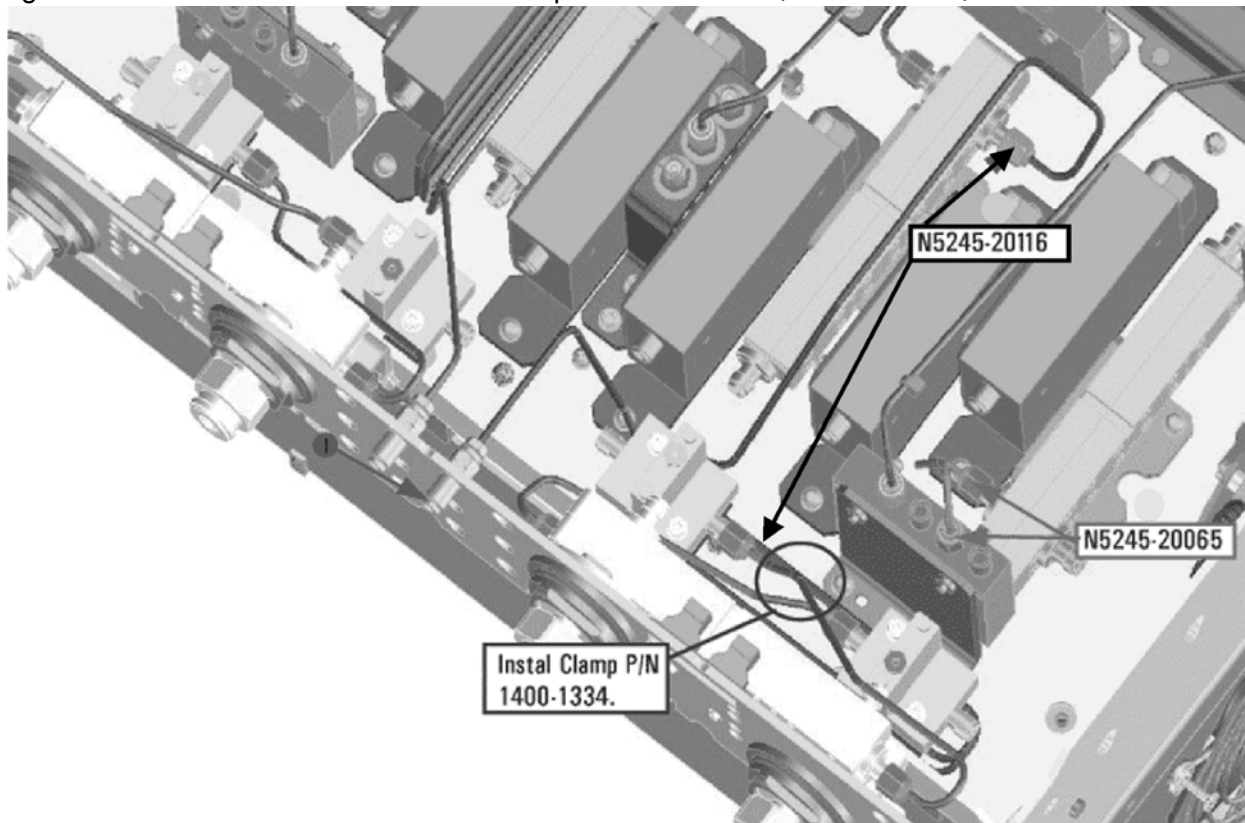

N5245_010_02

- W106 (reuse) N5245-20065 A50 port 1 mechanical switch to A29 port 1 reference coupler
- W89 (N5245-20026)A31 port 4 reference coupler to A40 port 4 source attenuator
- W85 (N5245-20026)A30 port 3 reference coupler to A39 port 3 source attenuator
- W93 (reuse) (N5245-20029)A32 port 2 reference coupler to A41 port 2 source attenuator
- W81 (reuse) (N5245-20029)A29 port 1 reference coupler to A38 port 1 source attenuator

Installation Procedure for the Upgrade

- W103 (reuse) (N5245-20055)Port 2 RCVR B IN to A49 port 2 receiver attenuator
- W95 (reuse) (N5245-20030)Port 2 CPLR THRU to A45 port 2 bias tee
- W34 (N5245-20019)A36 port 2 coupler to front-panel Port 2 CPLR ARM
- W94 (reuse) (N5245-20031)A41 port 2 source attenuator to front-panel Port 2 SOURCE OUT
- W33 (reuse) (N5245-20010)A32 port 2 ref coupler to front-panel REF 2 SOURCE OUT
- W46 (N5245-20115)REF 2 RCVR R2 IN to A27 mixer brick (R2)
 - * Connect W46 to top R2 connector on the mixer bricks.
- W30 (N5245-20018)A35 port 4 coupler to front-panel Port 4 CPLR ARM
- W101 (N5245-20074)Port 4 RCVR D IN to A48 port 4 receiver attenuator
- W90 (N5245-20028)A40 port 4 source attenuator to front-panel Port 4 SOURCE OUT
- W91 (N5245-20090)Port 4 CPLR THRU to A44 port 4 bias tee
- W45 (N5245-20021)REF 4 RCVR R4 IN to A69 3 dB pad on A28 mixer brick (R4)
- W29 (N5245-20117)A31 port 4 ref coupler to front-panel REF 4 SOURCE OUT
 - * As shown in **Figure 11**, install clamp part number 1400-1334 to secure W29

Figure 11

Location of Cable Clamp to Secure W29 (N5245-20117)

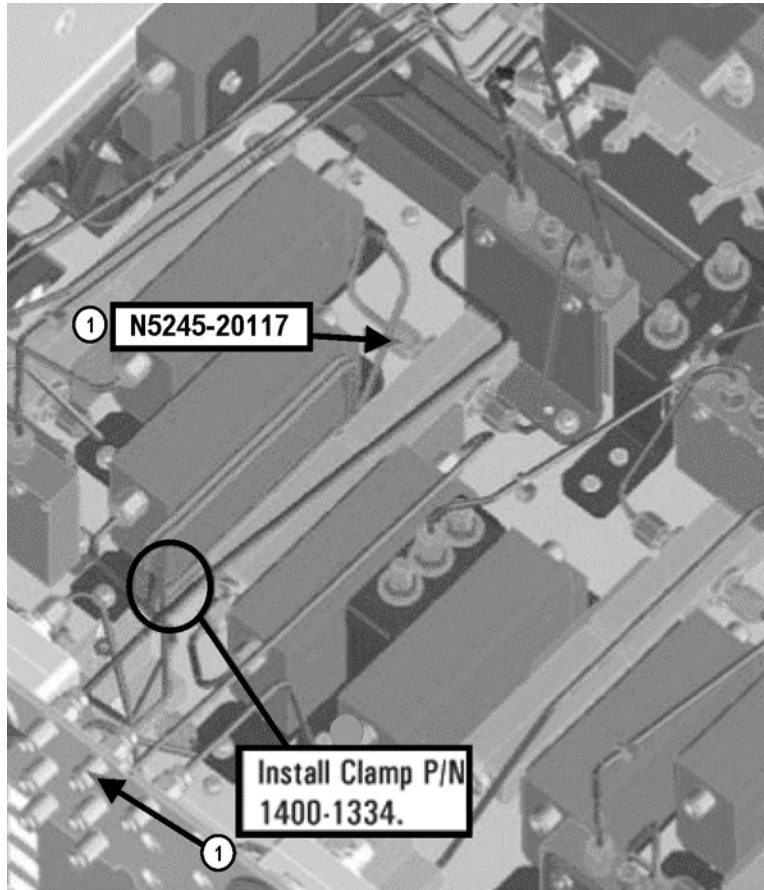

N5245_010_01

- W99 (N5245-20073) Port 3 RCVR C IN to A47 port 3 receiver attenuator
- W87 (N5245-20089) Port 3 CPLR THRU to A43 port 3 bias tee
- W26 (N5245-20015) A34 port 3 coupler to front-panel Port 3 CPLR AR
- W86 (N5245-20027) A39 port 3 source attenuator to front-panel Port 3 SOURCE OUT
- W44 (N5245-20020) REF 3 RCVR R3 IN to A28 mixer brick (R3)
 - * Connect W44 to top R3 connector on the mixer bricks.
- W83 (reuse) (N5245-20076) Front-panel Port 1 CPLR THRU to A42 port 1 bias tee
- W22 (N5245-20014) A33 port 1 coupler to front-panel Port 1 CPLR ARM
- W97 (reuse) (N5245-20054) Front-panel Port 1 RCVR A IN to A46 port 1 receiver attenuator
- W82 (reuse) (N5245-20077) A38 port 1 source attenuator to front-panel Port 1 SOURCE OUT

Installation Procedure for the Upgrade

- W42 (reuse) (N5245-20007)REF 1 RCVR R1 IN to A37 reference mixer switch
 - W21 (N5245-20008)A29 port 1 reference coupler to A37 reference mixer switch
- * As shown in **Figure 12**, install cable tie part number 1400-0249 to secure W21.

Figure12 Location of Cable Tie to Secure W21 (N5245-20008)

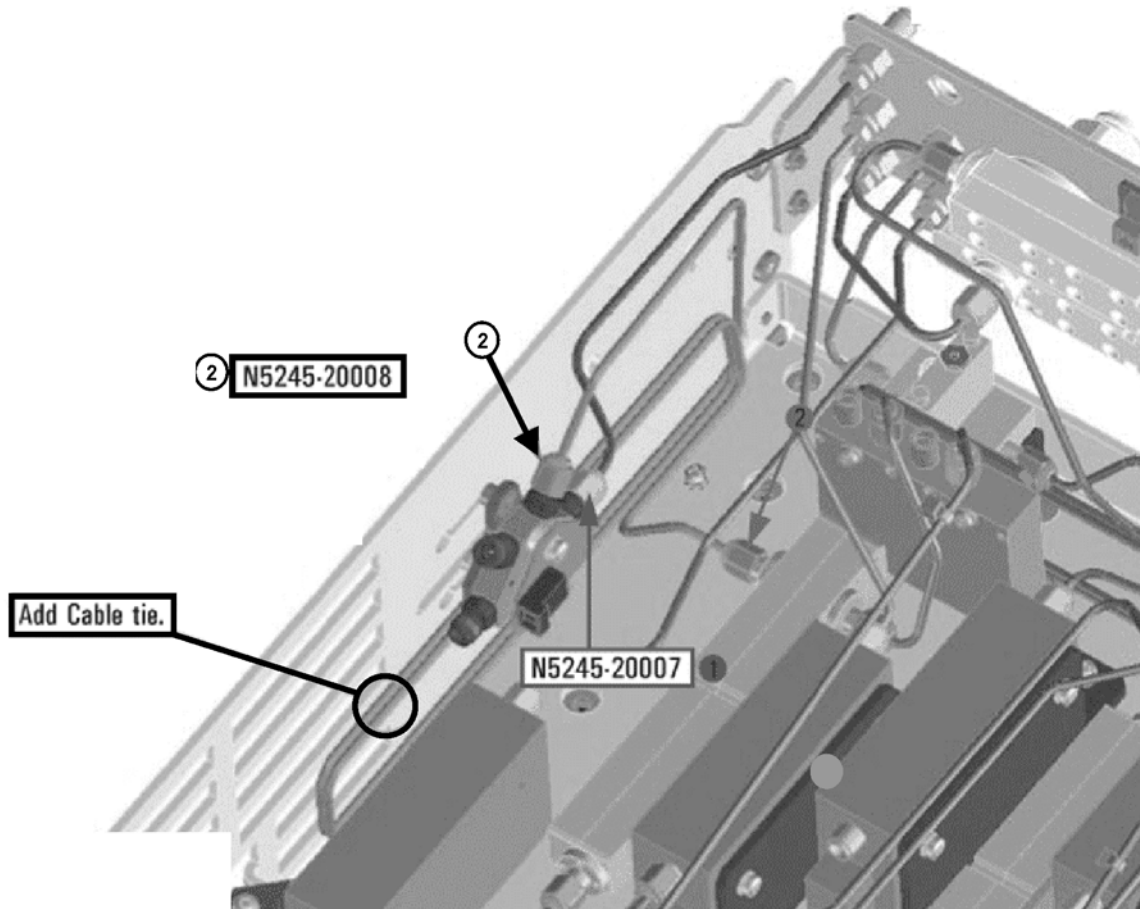

N5245

- W43 (reuse) N5245-20009)A37 reference mixer switch to A27 mixer brick (R1)
- * Connect W43 to bottom R1 connector on the mixer bricks.
- W41 (reuse) (N5245-20006)A37 reference mixer switch to front-panel REF 1 SOURCE OUT
 - W119 reuse) (N5245-20063)A53 port 2 mechanical switch to W17
 - W105 (reuse) (N5245-20064)A50 port 1 mechanical switch to W11

Installation Procedure for the Upgrade

- W110 (reuse) (N5245-20067) 50 port 1 mechanical switch to A54 combiner
- W102 (N5245-20075)A48 port 4 receiver attenuator to A28 mixer brick (D)
 - * Connect W102 to top D connector on the mixer bricks.
- W100 (N5245-20066)A47 port 3 receiver attenuator to A28 mixer brick (C)
 - * Connect W100 to bottom C connector on the mixer bricks.
- W115 (N5245-20060)A52 port 4 mechanical switch to W15
- W111 (reuse) (N5245-20058)A51 port 3 mechanical switch to W13
- W104 (reuse) (N5245-20057)A49 port 2 receiver attenuator to A27 mixer brick (B)
 - * Connect W104 to bottom B connector on the mixer bricks
- W98 (reuse) (N5245-20056)A46 port 1 receiver attenuator to A27 mixer brick (A)
 - * Connect W98 to top A connector on the mixer bricks.
- W54 (N5245-20022)A26 splitter to A28 mixer brick
- W53 (N5245-20023)A26 splitter to A27 mixer brick
- W52 (N5245-20013)A25 HMA26.5 to A26 splitter
- W58 (N5245-20095)A28 mixer brick to 50 ohm load (1810-0118)
 - * After installing W58 to the mixer brick, attach the new 50 ohm load (1810-0118) using a 1/4 inch open end wrench to hold cable W58 in place.
 - * Torque A26 splitter screws to 6 in-lbs.
- W70 (N5242-60013) A20 IF multiplexer (P203) to A12 SPAM (J2)
- W72 (N5242-60015) A20 IF multiplexer (P603) to A12 SPAM (J5)

Step 25. Secure the Front Panel Bulkhead Connectors

Follow the instruction shown in **Figure 13** in this document.

Figure 13 Bulkhead Connections, Front Panel

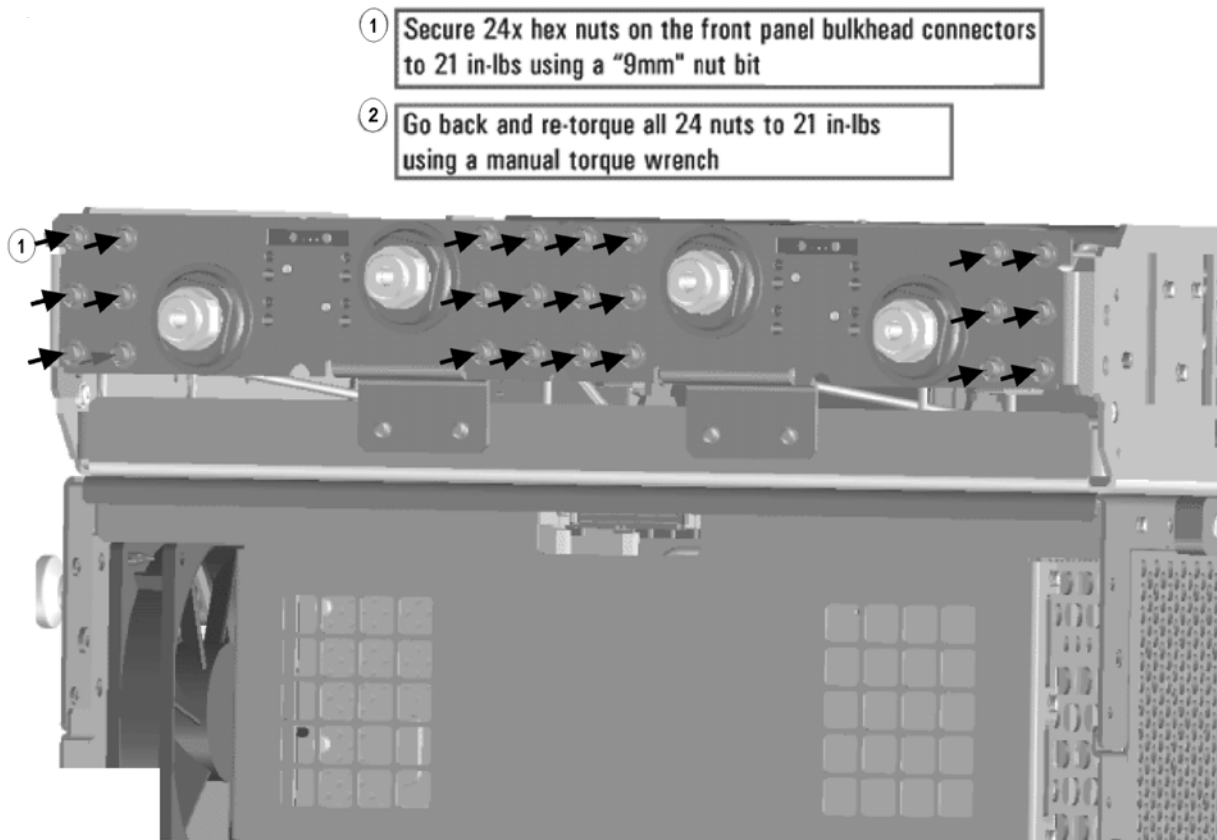

N5245_017

Step 26. Reinstall the A24 IF Multiplexer Board

For instructions, click the Chapter 7 bookmark "Removing and Replacing the A24 IF Multiplexer Board" in the PDF Service Guide¹.

Step 27. Reinstall the A23 Test Set Motherboard

CAUTION

Follow instructions carefully when making cable connections, especially wire harness connections. Incorrect connections can destroy components, resulting in additional customer costs.

1. For instructions on reinstalling the board, click the Chapter 7 bookmark "Removing and Replacing the A23 test set motherboard" in the PDF Service Guide¹.

1. See ["Downloading the Online PNA Service Guide" on page 6](#).

2. If not already done in a previous step, install the following new ribbon cables and wire harness in the order listed. To see an image showing their locations, click the Chapter 6 bookmark “Bottom Ribbon Cables and Wire Harnesses, 4-Port, Option 423” in the PDF Service Guide¹. New parts are listed in **Table 1 on page 8**.
 - Ribbon cable, N5247-60015 from A23 test set motherboard J552 to A28 mixer brick (2) J52
 - Ribbon cable (part of bias tee assembly), port 3 bias tee to A23 test set motherboard J543
 - Ribbon cable (part of bias tee assembly), port 4 bias tee to A23 test set motherboard J544
 - Ribbon cable (N5245-60026), A23 test set motherboard J206 to A47 port 3 receiver attenuator
 - Ribbon cable (N5245-60026), A23 test set motherboard J207 to A48 port 4 receiver attenuator
 - Ribbon cable (N5245-60006), A23 test set motherboard J547 to A39 port 3 source attenuator
 - Ribbon cable (N5245-60006), A23 test set motherboard J548 to A40 port 4 source attenuator
 - Wire harness (part of mechanical switch assembly), A23 test set motherboard J103 to A48 port 4 mechanical switch
 - Wire harness (N5225-60001), A23 test set motherboard J221 to ports 1/3 LED board J1
 - Wire harness (N5225-60001), A23 test set motherboard J222 to ports 2/4 LED board J1

Step 28. Disassemble the 2-Port Front Panel and Assemble the 4-Port Front Panel

Before the front frame can be replaced, the items making up the back side of the front panel assembly must be removed. For instructions on removing these items, click the Chapter 7 bookmark “Removing and Replacing the A1-A3 and Other Front Panel Subassemblies” in the PDF Service Guide¹. New parts are listed in **Table 1 on page 8**.

1. In the section “Removing the A2 USB Board,” perform the only step.
2. In the section “Removing the A1 Front Panel Interface Board and Keypad Assembly,” perform steps 1 - 5.
3. In the section “Removing the Power Switch Board and Power Button Keypad,” perform only steps 1 and 2.

1. See “**Downloading the Online PNA Service Guide**” on page 6.

4. Remove the braided gasket from the backside edges of the 2-port front frame and install it in the 4-port front frame (N5247-20141).
5. Rebuild the front panel assembly with the new 4-port front frame (N5247-20141) by reversing the order of the instructions previously followed.

Step 29. Reinstall Front Panel Assembly

For instructions on reinstalling the front panel assembly, click the Chapter 7 bookmark “Removing and Replacing the Front Panel Assembly” in the PDF Service Guide¹.

In addition, attach the lower front dress panel to the test set front plate using 4x screws 0515-1227.

Step 30. Install the Overlays

To see an image of the front panel overlay (N5242-80003), keypad overlay (N5242-80005), and power button overlay (N5242-80007), click the Chapter 6 bookmark “Front Panel Assembly, Front Side, All Options” in the PDF Service Guide¹. New parts are listed in [Table 1 on page 8](#).

1. Remove the protective backing from the new front panel overlay (N5242-80003).
2. Loosely place the overlay in the recess on the lower front panel.
3. Placing two fingers at the middle, press the overlay firmly onto the frame while sliding your fingers in opposite directions towards the ends of the overlay. Repeat on all areas of the overlay.
4. Repeat steps 1-3 to install the keypad overlay (N5242-80005).
5. Repeat steps 1-3 to install the power button overlay (N5242-80007).
6. Install the new nameplate (N5245-80003).

Step 31. Install the Jumper Cables and Rear Panel Termination

- Install twelve W36 front panel jumper cables (N5245-20104) - use 6 old jumpers and 6 new jumpers. To see an image of the front panel jumper cables, click the Chapter 7 bookmark “Removing and Replacing the Front Panel Assembly” in the PDF Service Guide¹.
- Install new W123 rear panel jumper cable (N5245-20155) from SW SRC OUT (J4) to SW TSET IN (J3). To see an image showing the location of this rear panel jumper, click on the Chapter 6 bookmark “Rear Panel Assembly, All Options” in the PDF Service Guide¹.
- Install the 2.4 mm 50 GHz termination (0955-2394) on rear panel J7, port 3.

1. See [“Downloading the Online PNA Service Guide” on page 6](#).

Step 32. Position the Cables and Wires to Prevent Pinching

On the top side of the PNA, carefully position the grey flex cables so they can't be pinched between the covers and the rails.

On the bottom side of the PNA, carefully fold or push down the ribbon cables and wires so they can't be pinched between the hardware and the outer cover. Ribbon cables and wires must never be positioned on top of hardware.

Step 33. Reinstall the Inner Cover

For instructions, click the Chapter 7 bookmark "Removing the Covers" in the PDF Service Guide¹.

Step 34. Reinstall the Outer Cover

For instructions, click the Chapter 7 bookmark "Removing the Covers" in the PDF Service Guide¹.

Step 35. Remove Option 224 and Option 219 Licenses

Procedure Requirements

- The analyzer must be powered up and operating to perform this procedure.
- The Network Analyzer program must be running.
- A keyboard and mouse must be connected to the network analyzer.

Option 224 and Option 219 License Removal Procedure

1. To start the option enable utility, press UTILITY **System**, then **Service**, then **Option Enable**. An option enable dialog box will appear.
2. Click the arrow in the **Select Desired Option** box. A list of available options will appear.
3. In the **Select Desired Option** list, click **224**.
4. Click **Remove**.
5. Click **OK** to confirm that you want to remove the license for the selected option.
6. Click **No** in answer to the displayed question in the **Restart Analyzer?** box.
7. Click the arrow in the **Select Desired Option** box. A list of available options will appear.
8. In the **Select Desired Option** list, click **219**.
9. Click **Remove**.
10. Click **OK** to confirm that you want to remove the license for the selected option.

11. Click **Yes** in answer to the displayed question in the **Restart Analyzer?** box.

Step 36. Enable Options P04, 419, and 423

Procedure Requirements

- The analyzer must be powered up and operating to perform this procedure.
- The Network Analyzer program must be running.
- A keyboard and mouse must be connected to the network analyzer.

Option Enable Procedure

1. To start the option enable utility, press **UTILITY** **System**, then **Service**, then **Option Enable**. An option enable dialog box will appear.
2. Click the arrow in the **Select Desired Option** box. A list of available options will appear.
3. In the **Select Desired Option** list, click **P04 - 4-Ports**.
4. Using the keyboard, enter the license key in the box provided. The license key is printed on the license message you received from Keysight. Enter this key exactly as it is printed on the message.
5. Click **Enable**.
6. Click **Yes** in answer to the displayed question in the **Restart Analyzer?** box.
7. Repeat steps 3-6 to enable Option 419, clicking **419 - Src/Rcvr Atten & Bias Ts 4-Port** in step 3.
8. Repeat steps 3-6 to enable Option 423, clicking **423 - Combiner & Switches** in step 3.
9. When the installation is complete, click **Exit**.

Option Verification Procedure

Once the analyzer has restarted and the Network Analyzer program is again running:

1. On the analyzer's Help menu, click **About Network Analyzer**.
2. Verify that "P04," "419," and "423" are listed, but "224" and "219" are not listed after "Options:" in the display. Click **OK**.

NOTE

If the options have not been enabled or if the option 224 and option 219 licenses have not been removed, perform the prior steps again. If the options are still not correct, contact Keysight Technologies. Refer to ["Getting Assistance from Keysight" on page 4](#).

Step 37. Perform Post-Upgrade Adjustments and Calibration

Adjustments

The following adjustments must be made due to the hardware changes of the analyzer.

- source adjustment
- IF gain adjustment
- receiver adjustment
- receiver characterization

These adjustments are described in the PNA Service Guide and in the PNA on-line HELP. A list of equipment required to perform these adjustments is also found in the service guide.

After the specified adjustments have been performed, the analyzer should operate and phase lock over its entire frequency range.

Operator's Check

Perform the Operator's Check to check the basic functionality of the analyzer. For instructions, click the Chapter 3 bookmark "Tests and Adjustments" in the PDF Service Guide¹.

If you experience difficulty with the basic functioning of the analyzer, contact Keysight. Refer to **"Contacting Keysight" on page 4**.

Calibration

Although the analyzer functions, its performance relative to its specifications has not been verified. It is recommended that a full instrument calibration be performed using the analyzer's internal performance test software. To view information on the performance test software, click the Chapter 3 bookmark "Tests and Adjustments" in the PDF Service Guide¹.

Step 38. Prepare the PNA for the User

- 1. If necessary, reinstall front jumper cables.**
- 2. Install the cable guards, pushing them over the front jumper cables until the cushioning material touches the front panel of the PNA.**
- 3. Install the dust caps on the test ports.**
- 4. Clean the analyzer, as needed, using a damp cloth.**

1. See **"Downloading the Online PNA Service Guide" on page 6**.

This information is subject to change without notice.

© Keysight Technologies 2008 – 2015

August 2015



N5245-90010
www.keysight.com